

LamaCaster H65



Titus Technologies

Advanced Multi-Slide Die Casting Technology



LamaCaster H65

Hydraulic Multi-Slide Die Casting Machine

Description

The LamaCaster H65 machine is a powerful and precise hydraulic multi-slide die casting machine with an 8-tonne clamping force running 65mm x 65mm tooling. The machine is ideal for making

small parts with demanding quality requirements, thin wall sections, high integrity and plating quality finishes.

Features

- reliable and robust multi-slide die casting machine
- high productivity rates - fast cycling with quick tool changes
- compact machine footprint
- split-line injection optimises material usage
- touchscreen controller with process visualisation
- six programmable hydraulic functions/four pneumatic
- integrated ingot feeding

Technical Specification

Item	
locking force	8 tonnes
tool size	65mm x 65mm 100mm x 65mm
shot weight	up to 90g
dry cycle speed	60 cycles/min

The H65 machine runs with 65mm x 65mm tools as standard or can be configured for 100mm x 65mm tooling. The H65 is very flexible and can either produce larger components from single cavity tools or small components on multi-cavity tools. This machine produces castings with minimal porosity and excellent surface finish.

The H65 machine is very versatile and has the capability of running complex tool sequences as it has six programmable hydraulic functions and four programmable auxiliary pneumatic functions enabling the production of very complex geometry components. The H65 controller has been designed for ease of use with the

functionality to control the whole of the casting process and give maximum operator feedback to ensure optimum levels of productivity and quality can be achieved.

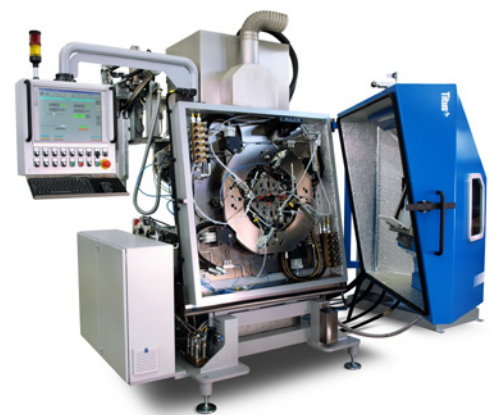

LamaCaster H65

Item	Metric		US	
	Standard	Option	Standard	Option
Slider Movement/ Tool				
No. of slides	4	6	4	6
Max. stroke (theoretical)	5mm		1,98"	
Nominal die size	65mm x 65mm	100mm x 65mm	2.56" x 2.56"	3.94" x 2.56"
Locking force	8t		8.8t	
No. of cavities in tool	na	na	na	na
Melt Pot				
Heater power	20kW		20kW	
Melt rate	105kg/h		231lbs/h	
Melt pot capacity	160kg		353lbs	
Cooling				
Supply of treated water	3 bar		43.5 psi	
Reccomended water temperature	13 to 18°C		55 to 65F	
Pneumatics				
Line pressure (max.)	6 bar		87 psi	
Air consumption (max.)	25m³/h		14.7cfm	
Capacity of air reservoirs	na		na	
Dry cycle speed (cycles/min.)	60		60	
Hydraulics				
Line pressure (max.)	110 bar	130 bar	1595 psi	1885 psi
Hydraulic tank capacity	150l		39.6 gallons	
Motor power	11kW		14.75hp	
Injection				
Injection piston diameter	25.4mm	40mm	1"	1.57"
Injection cylinder diameter	63mm		2.48"	
Max. injection cylinder stroke	45mm		1.77"	
Max. shot weight (theoretical)	150g	370g	5.3oz	13oz
Max. recommended shot weight	90g	220g	3.2oz	7.8oz
Max. recommended metal pressure	350 bar	290 bar	5076 psi	4206 psi
Nozzle				
Heater power	1100W		1100W	
Power Supply				
Voltage	3 x 400V 50Hz		3 x 400V 50Hz	
Nominal power	35kW		35kW	
Nominal current	50A		50A	
Pre-fuse max.	63A		63A	
Connection type	TN-S, 3+N+PE		TN-S, 3+N+PE	

na* = not applicable

LamaCaster H65

Hydraulic Multi-Slide Die Casting Machine

Footprint

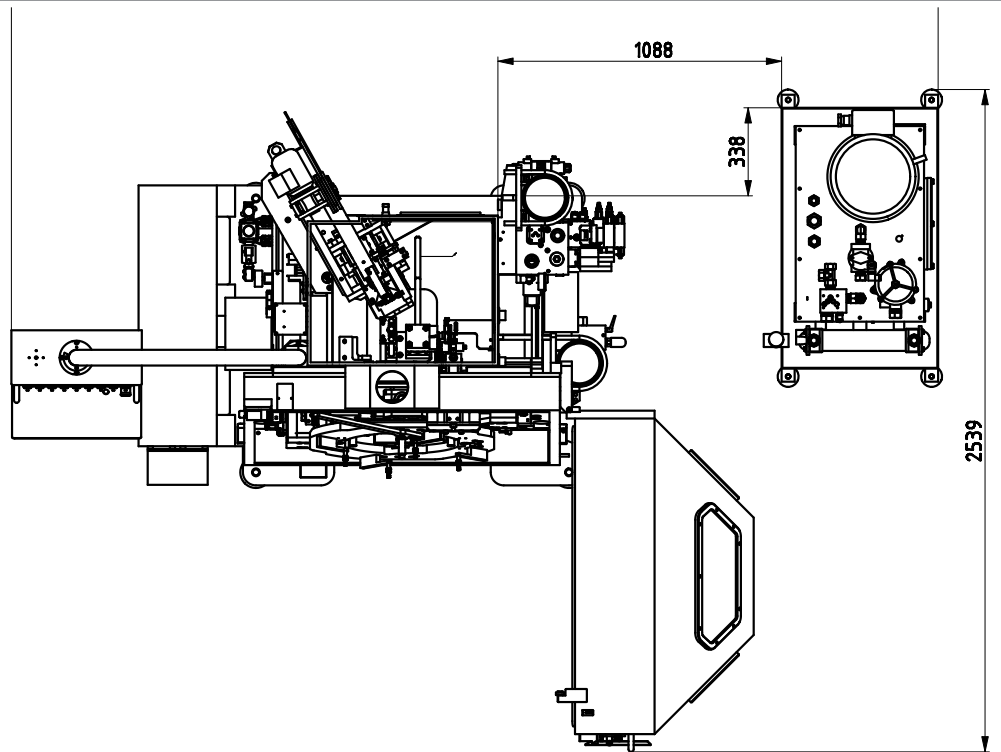

The H65 machine is a compact machine with a small footprint. Attention should be given to any other equipment, walls or other objects that are situated close to where the machine is to be positioned. To the rear of the machine there should be a minimum clearance of one metre to allow for access to the melt pot, injection unit etc. and space should be allowed for any lifting equipment and personnel that are required to carry out normal machine operation and maintenance tasks on and around the machine.

Service requirements

Water 3-5 bar @ 13-18°C

Air 25m³/h @ 6-8 bar max.

Power supply 35kW

